

# ELECTRIC BOOSTER HEATER

FOR 180°F SANITIZING RINSE WATER

Model J

## FEATURES

### ▪ Heavy Duty Construction

- All stainless steel tank construction does not require an internal lining
- ASME Section VIII stamped construction provides for extended tank life
- Entire exterior is 304 brushed stainless steel for improved appearance and longevity
- Gasketed front cover minimizes water intrusion to increase service life

### ▪ Advanced Design

- Advanced electronic temperature control with digital display confirms at a glance proper operation and temperature setting
- Visual indication of fault conditions provides instant feedback
- Electronic leak detection system notifies user in the event of an internal water leak
- Factory packaged resettable circuit breakers for internal over current protection save time and money compared to one shot fuses
- A bronze body (not cast iron) pressure reducing valve is factory supplied with each booster.
- Designed for ease of service, no electrical component needs to be removed to replace any other part

### ▪ Reliable

- Overall dimensions and connection locations are compatible with other popular brands to facilitate direct replacement without modification to the existing plumbing.
- Molded rigid polyurethane foam insulation minimizes tank heat loss for maximum operating efficiency and reduced operating costs



Model J

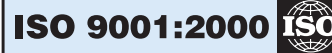

- Screw plug elements with O-ring gasket reduce leakage problems associated with less reliable and more difficult to service flange type heating elements.
- Full ten (10) year (non pro-rated) tank warranty

## A LONG LASTING BOOSTER HEATER

The Hubbell J model is the longest lasting booster heater available because it utilizes a heavy duty ASME Section VIII designed, constructed and stamped all stainless steel tank which does not require an internal tank lining. Other manufacturers use a non ASME steel tank with an internal lining which is easily eroded in high temperature water and eventually leaves the bare steel tank exposed to the corrosive effects of water. Once this occurs it is only a short time before a steel tank will begin to rust, leak, and need replacement. Hubbell did not stop at improving just the tank design. For improved appearance and longevity the Hubbell booster comes standard with a brushed 304 stainless steel outer jacket

and base which is impervious to the corrosive effects of water and looks great in your kitchen. The Hubbell booster is also equipped as standard with the advanced functionality of an electronic temperature controller to provide accurate, reliable and energy efficient operation while simplifying service work. The Hubbell booster's polyurethane foam insulation also improves operating efficiency and reduces the cost of operation. When you specify and install a Hubbell booster heater, you will have confidence in knowing that the owner will be provided with a long lasting and trouble-free source for 180°F water.

THE HUBBELL BOOSTER: A LEAP AHEAD

**Hubbell**™

# WHY INSTALL A HUBBELL BOOSTER WATER HEATER?

## 1 Improved Longevity

The Hubbell booster heater is designed to provide many years of operation. The tank is all stainless steel construction and is designed, constructed and stamped in strict conformance to ASME Section VIII.

## 2 Lower Operating Costs

The Hubbell booster tank is encapsulated in rigid polyurethane foam insulation to minimize stand-by heat loss. This high quality insulation reduces heat loss by more than 61% compared to fiberglass type insulation found in other brands. The result is that an average Hubbell booster heater owner can expect to save over \$119 per year in operating costs compared to other brands.

## 3 Reduced Service and Maintenance Costs

Hubbell has greatly simplified booster heater service and maintenance through numerous advancements in booster design and controls. The Hubbell controller is a major step forward with improved ease of use and service. The digital display provides the owner and technician with visual error indication. The controller can be set to the exact desired temperature in degrees – no more hotter/colder calibration. It also includes a leak detection system to notify the user in the event of an internal leak. For further ease of service and maintenance, all controls are mounted such that when a component is removed for service no other component needs to be removed, and all sensing functions have been consolidated into one probe. The heating element and sensing probe are straight thread screw types that utilize an O-ring to minimize leakage problems as is common with flat gaskets and NPT connections.

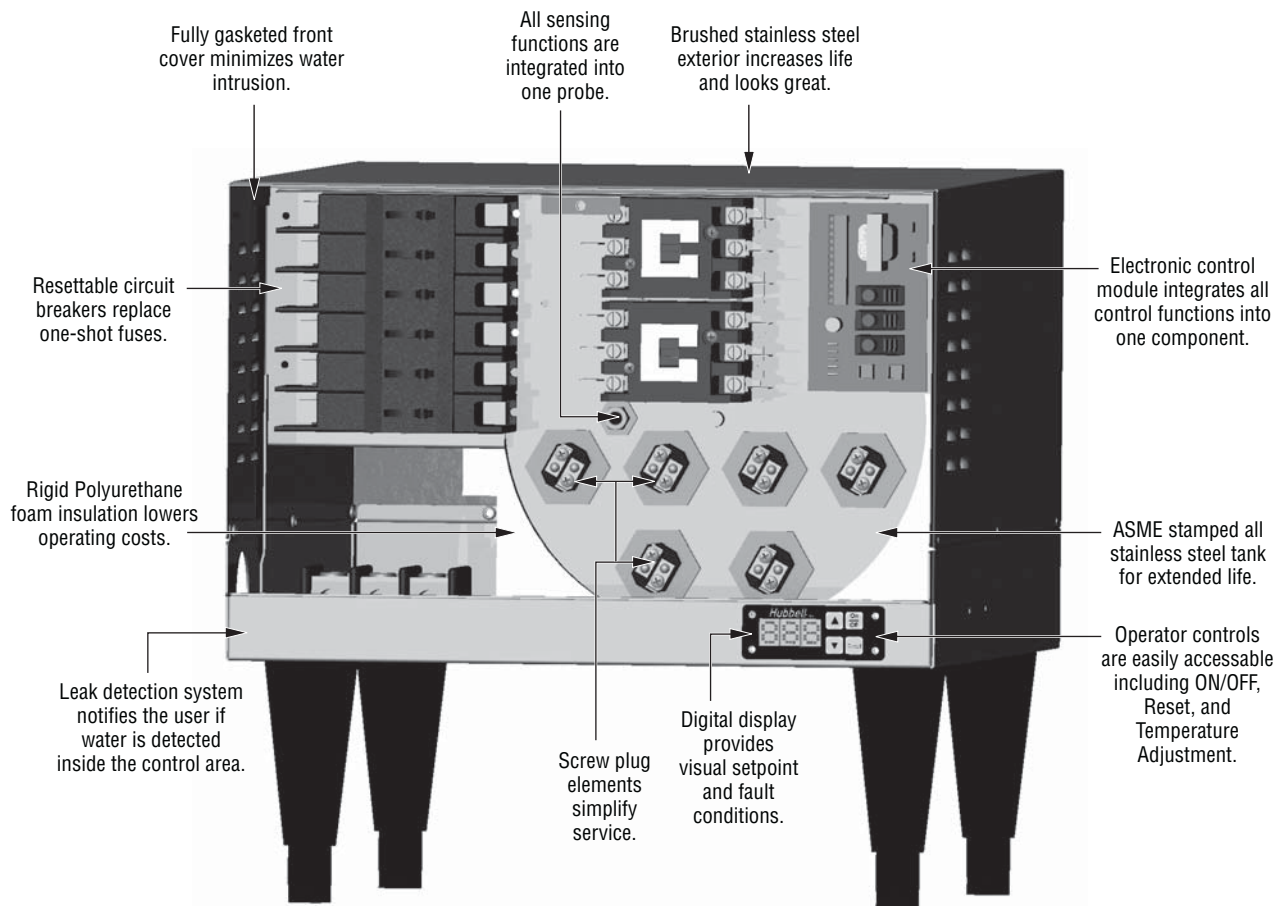

Note: All components are removable without disturbing any other component.

# MODEL NUMBER SELECTION CHART WITH AMPERAGE

Base Model	KW Rating	Storage Capacity (Gallons)	Full Model Number Listed By Voltage & Phase						Amperage Draw By Voltage & Phase					
			208 V		240 V		480 V		208 V		240 V		480 V	
			1Φ	3Φ	1Φ	3Φ	3Φ	1Φ	1Φ	3Φ	1Φ	3Φ	3Φ	1Φ
J6	4	6	J64RS	—	J64S	—	—	J64T4S	19	—	17	—	—	9
	5		J65RS	—	J65S	—	—	J65T4S	24	—	21	—	—	11
	6		J66RS	J66R	J66S	J66T	J66T4	—	29	17	25	14	7	—
	7		J67RS	J67R	J67S	J67T	J67T4	—	34	19	29	17	8	—
	9		J69RS	J69R	J69S	J69T	J69T4	—	43	25	38	22	11	—
	12		J612RS	J612R	J612S	J612T	J612T4	—	58	33	50	29	14	—
	13.5		J613RS	J613R	J613S	J613T	J613T4	—	65	38	56	33	16	—
	15		J615RS	J615R	J615S	J615T	J615T4	—	72	42	63	36	18	—
	18		J618RS	J618R	J618S	J618T	J618T4	—	87	50	75	43	22	—
	24		J624RS	J624R	J624S	J624T	J624T4	—	115	67	100	58	29	—
	27		J627RS	J627R	J627S	J627T	J627T4	—	130	75	113	65	33	—
	30		J630RS	J630R	J630S	J630T	J630T4	—	144	83	125	72	36	—
	36		J636RS	J636R	J636S	J636T	J636T4	—	173	100	150	87	43	—
	39		J639RS	J639R	J639S	J639T	J639T4	—	188	108	163	94	47	—
	45		—	J645R	J645S	J645T	J645T4	—	—	125	188	108	54	—
54	—	J654R	—	J654T	J654T4	—	—	150	—	130	65	—		
58.5	—	J658R	—	J658T	J658T4	—	—	163	—	141	70	—		
J16	4	16	J164RS	—	J164S	—	—	J164T4S	19	—	17	—	—	—
	5		J165RS	—	J165S	—	—	J165T4S	24	—	21	—	—	—
	6		J166RS	J166R	J166S	J166T	J166T4	—	29	17	25	14	7	—
	7		J167RS	J167R	J167S	J167T	J167T4	—	34	19	29	17	8	—
	9		J169RS	J169R	J169S	J169T	J169T4	—	43	25	38	22	11	—
	12		J1612RS	J1612R	J1612S	J1612T	J1612T4	—	58	33	50	29	14	—
	13.5		J1613RS	J1613R	J1613S	J1613T	J1613T4	—	65	38	56	33	16	—
	15		J1615RS	J1615R	J1615S	J1615T	J1615T4	—	72	42	63	36	18	—
	18		J1618RS	J1618R	J1618S	J1618T	J1618T4	—	87	50	75	43	22	—
	24		J1624RS	J1624R	J1624S	J1624T	J1624T4	—	115	67	100	58	29	—
	27		J1627RS	J1627R	J1627S	J1627T	J1627T4	—	130	75	113	65	33	—
	30		J1630RS	J1630R	J1630S	J1630T	J1630T4	—	144	83	125	72	36	—
	36		J1636RS	J1636R	J1636S	J1636T	J1636T4	—	173	100	150	87	43	—
	39		J1639RS	J1639R	J1639S	J1639T	J1639T4	—	188	108	163	94	47	—
	45		—	J1645R	J1645S	J1645T	J1645T4	—	—	125	188	108	54	—
54	—	J1654R	—	J1654T	J1654T4	—	—	150	—	130	65	—		
58.5	—	J1658R	—	J1658T	J1658T4	—	—	163	—	141	70	—		

**Note:** The 6, 7, and 9kw models in 208 and 240 volt can be field converted from either 1 phase to 3 phase or from 3 phase to 1 phase. All 3 phase units are balanced 3 phase.

## RECOVERY RATINGS

KW Rating	Recovery Rate in GPH at °F Temperature Rise							
	20°	30°	40°	60°	70°	80°	110°	140°
4	82	55	41	27	23	20	16	12
5	102	68	51	34	29	26	20	15
6	123	82	61	41	35	31	25	18
7	143	96	72	48	41	36	29	20
9	184	123	92	61	53	46	37	26
12	246	164	123	82	70	61	49	35
13.5	276	184	138	92	79	69	55	39
15	307	205	154	102	88	77	61	44
18	368	246	184	123	105	92	74	53
24	491	328	246	164	140	123	98	70
27	553	368	276	184	158	138	111	79
30	614	409	307	205	175	154	123	88
36	737	491	368	246	211	184	147	105
39	798	532	399	266	228	200	160	114
45	921	614	461	307	263	230	184	132
54	1105	737	553	368	316	276	221	158
58.5	1198	798	599	399	342	299	240	171

## MODEL J6 - (4 TO 18 kW) DIMENSIONS



Shipping Weight: 95 lbs.

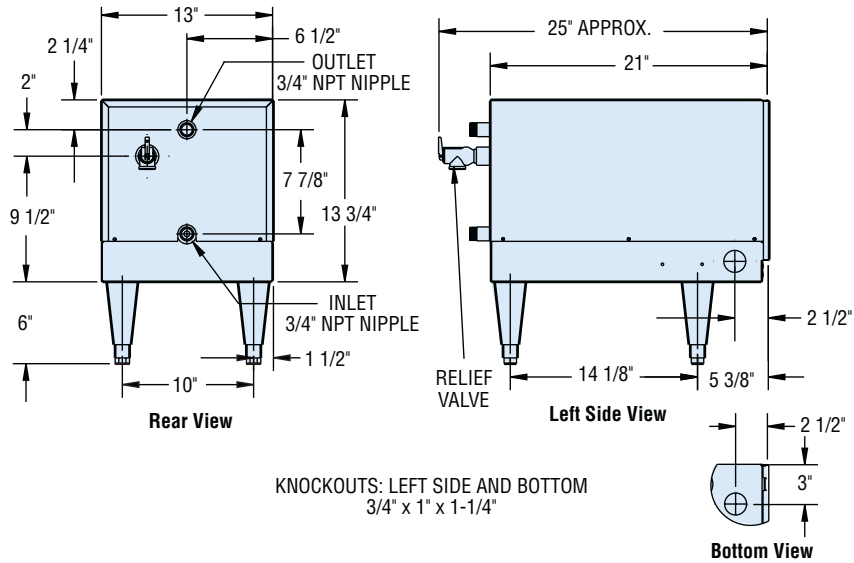

## MODEL J6 - (24 TO 58 kW) DIMENSIONS



Shipping Weight: 110 lbs.

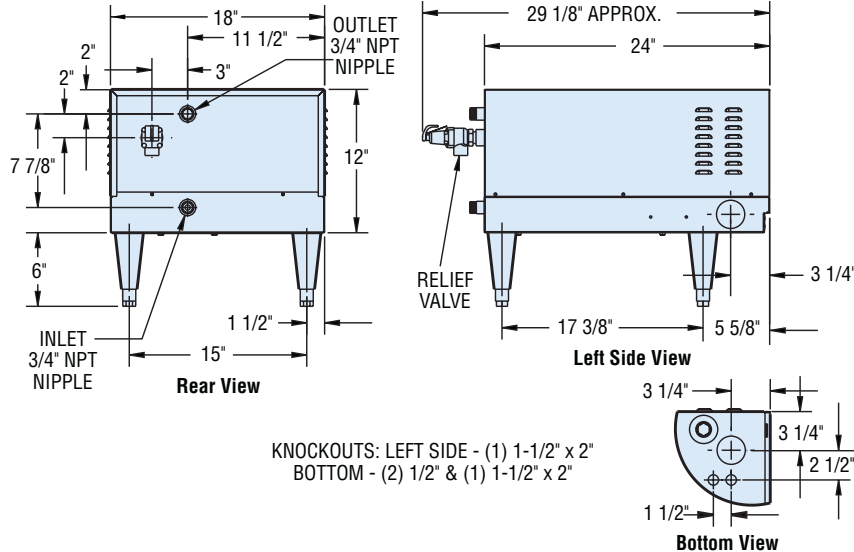

## MODEL J16 - DIMENSIONS



Shipping Weight: 140 lbs.

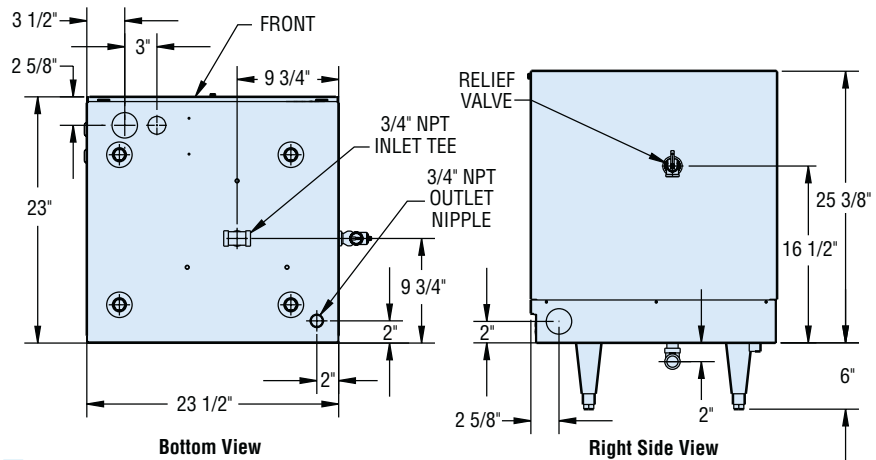

## TYPICAL INSTALLATION DIAGRAMS

### MODEL J16 (FRONT VIEW)

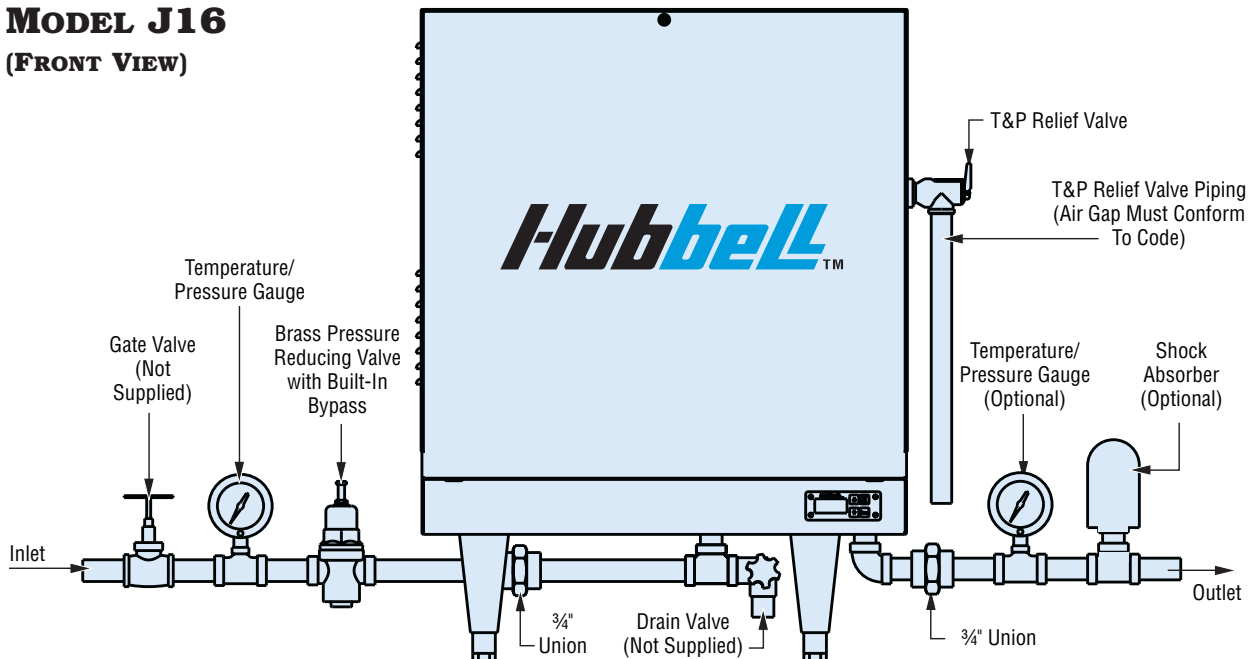

### MODEL J6 (REAR VIEW)

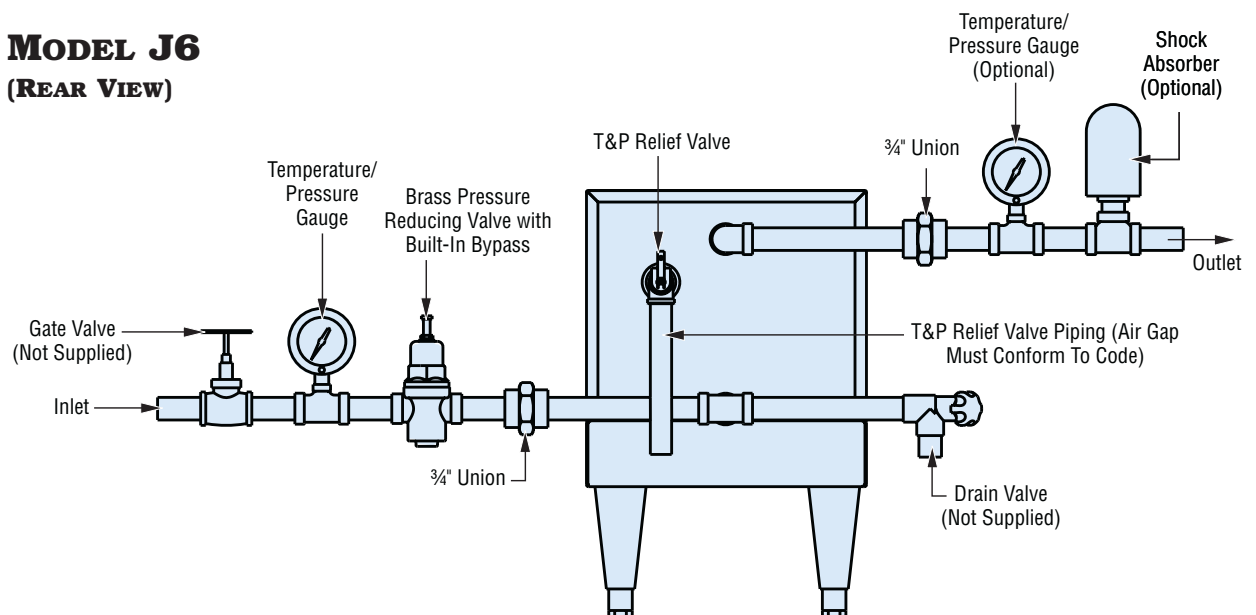

### PLUMBING NOTES:

1. Dielectric couplings should be used in connecting dissimilar metals to prevent electrolysis.
2. No check valve may be installed in the supply line to the booster.
3. All shut off valves must be gate or ball valves - not globe valves.
4. The brass pressure reducing valve with built-in bypass is adjustable from 10 to 35 psi.

## TYPICAL INSTALLATION DIAGRAMS

### J6 SLIDE BRACKET DETAIL

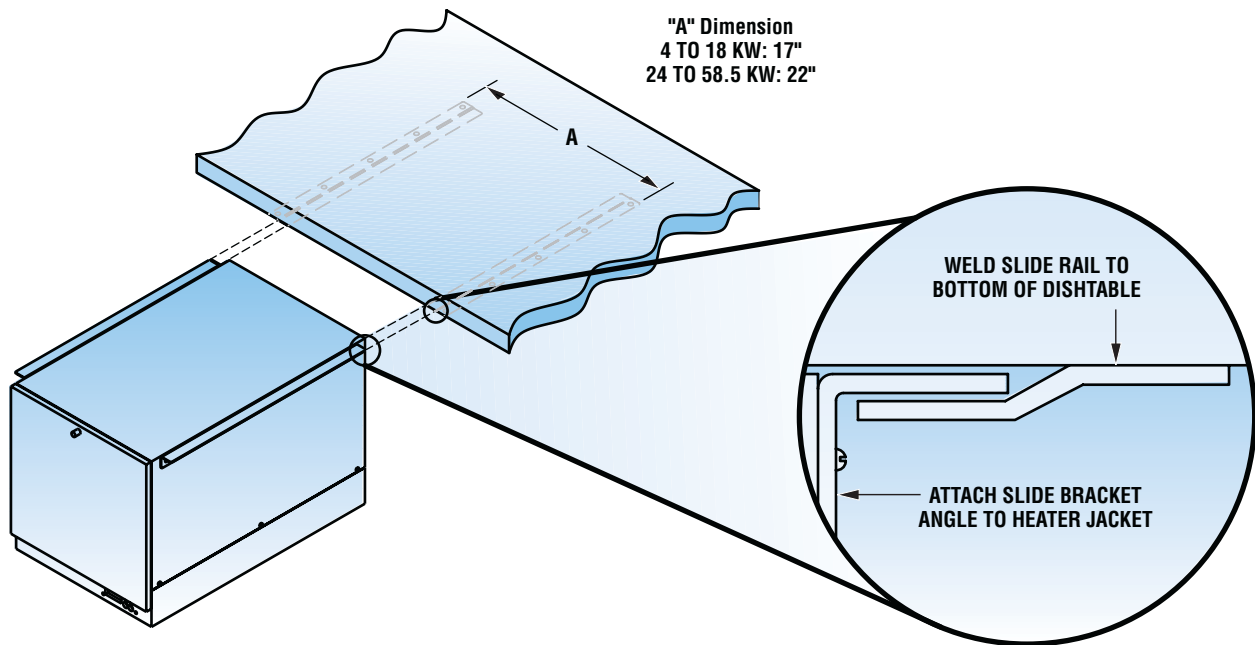

### OPTIONAL EQUIPMENT

- 1. Slide Brackets:** Available for the J6 model only, these brackets allow for mounting the booster heater under a counter. See slide bracket diagram for details.
- 2. Shock Absorber:** Reduce the harmful pressures resulting from quick closing dishwasher solenoid valves by installing a shock absorber between the booster and the dishwasher.
- 3. Floor Mounting Hardware:** Deck mounting legs are available for shipboard applications
- 4. Tamper Resistant Package:** For prison and other secure facilities a tamper resistant package is available
- 5. Nickel Plated Die-Cast Leg:** For an all stainless steel look these legs can be provided in lieu of the standard black plastic legs.
- 6. Alternate Voltage:** Voltages other than those shown in this brochure are available, including 380/415/440 volt and others. Consult factory for details.

### BOOSTER SIZING FOR A LOW TEMP DISHMACHINE

Chemical low-temp dishwashers are most effective when supplied with 140°F hot water. This water temperature may not be available due to an undersized primary water heater or local safety code. Hubbell J model boosters can operate as a pre-heater for chemical low-temp dishwashers to provide an adequate supply of 140°F hot water for proper operation.

To properly size a Hubbell booster heater for low temp use:

1. Determine the required temperature rise
2. Determine the water usage by consulting the dishwasher data plate, literature or NSF listing.
3. Select the appropriate kW based on 1 and 2 above.

# CHOOSING A MODEL WHEN YOU KNOW THE DISHWASHER BRAND USED

DISHWASHER - Model Number	40 °F Rise		70 °F Rise	
	6 Gallon	16 Gallon	6 Gallon	16 Gallon
	Model J6	Model J16	Model J6	Model J16
<b>ADAMATION</b>				
CSL-1390, CA-2, CA-3, CA-4, SLAP 44	J639	J1639	(2) J636	(2) J1636
CA, CA-1	J654	J1654	(2) J645	(2) J1645
<b>ALVEY</b>				
FLC-10, SL-2S		J166		J169
FLC-12, CL-1, CL-1Turntable, SA-5A		J167		J1612
FL-2S, VA-3A		J169		J1613
KS-70, KS-70N, KS70M SB		J169		J1615
VA-3A DBL		J169		J1618
SL-2D		J1613		J1618
FLC-36		J1615		J1627
KS-88		J1618		J1630
KS-70-N, KS-88-N		J1639		
<b>BLAKESLEE</b>				
UC-21	J66	J166	J612	J1612
D-8	J69	J169	J613	J1613
Series "R" & "F" -CC, -EE, -LL, -MM, -LLL, -MMM, -PCC, -PEE, -PLL, -PMM (multi-tank) with suffix "LC"	J613	J1613	J624	J1624
Series XF-LL, XF-PLL, XF-MM, XF-PMM, XF-EEE, XF-LLL, XF-MMM (Multi-tank) with suffix "LC"	J617	J1617	J630	J1630
DD-8	J618	J1618	J630	J1630
Series R-L, R-PL, R-M, R-PM, F-L, F-PL, F-M, F-PM (single tank)	J636	J1636	J654	J1654
Series XF-L, XF-PL, XF-M, XF-PM, (single tank)	(2) J636	(2) J1636		
Series XF-PEE, XF-PLL, XF-PMM, XF-EEE, XF-LLL, XF-MMM (multi tank)	J645	J1645	(2) J630	(2) J1630
NOTE: FA (Flight-A-Round) and RA (Rack-A-Round) use comparable "F" listing.				
<b>CHAMPION</b>				
UH1, UH150, UH200	J66	J166	J69	J169
DH1, DH1C, DH1-T, DH1-TC	J69	J169	J618	J1618
44WS, 66WS	J615	J1615	J627	J1627
PP28	J627	J1627	J645	J1645
40KB, 44KB, 54KB, 60KB, 64KB	J636	J1636	J658	J1658
UC-C	J645	J1645	(2) J636	(2) J1636
UC-CW ( 6 ft center max)	J658	J1658	(2) J640	(2) J1640
W-6-WS	J658	J1658	(2) J658	(2) J1658
<b>CMD DISH MACHINES</b>				
CMA-44H with tank heater	J624	J1624	J645	J1645
<b>HOBART</b>				
LX-30	J66	J166	J612	J1612
LX-18C, LX-30C, LX-40C, UM-4D, UMP-4D, WM-1D, WMP-1D, WM-5	J66	J166	J67	J167
LX-18	J69	J169	J615	J1615
WM-5C	J66	J166	J69	J169
SM-6T2	J66	J166	J612	J1612
WM-5 (SEE NOTE 1)	J67	J167	J612	J1612
AM-14T, AM-14F, AM-14TC	J69	J169	J612	J1612
UM-4, UMP-4, WM-1, WMP-1	J69	J169	J612	J1612
AM-12, AM-12C (SEE NOTE 2), AM-14, AM-14C	J69	J169	J612	J1612
C-44AW, CRS-66AW, CPW-80AW	J612	J1612	J615	J1615
UW-50		J1615		J1615
C-64W, CRS-86W, CPW-100W, C-88W, CRS-110W, CPW-124W	J624	J1624	J636	J1636
FT800W, FT-900W	J624	J1624	J639	J1639
C-64A, CRS-86A, CPW-100A, CMT-44	J636	J1636	J654	J1654
C-44, CRS-66, CPW-80, C-44A, CRS-66A, CRS-110A, CPW-80A, CPW-124A, C-88A	J636	J1636	J658	J1658
C-64, CRS-86, CPW-100	J645	J1645	(2) J636	(2) J1636
FT-600, FT-700, C-54, CRS-76, CPW-90	J654	J1654	(2) J639	(2) J1639
FT-300	J654	J1654	(2) J645	(2) J1640
FT800	J639	J1639	(2) J639	(2) J1639
FT-900	J639	J1639	(2) J636	(2) J1636
FT800S, FT-900S, CRS-76A, CPW-90A, C-54A	J639	J1639	(2) J639	(2) J1639
UTW-28, UTW-28C		J1618		J1636

FRC and FR (Fast Rack Series) use comparable J6 model listing.

NOTE 1: Without sump heater

NOTE 2: Model AM-12 with serial no. 12-067-357 or below and model AM-12C with serial no. 12-067-537 or below require slightly larger booster heater than listed.

DISHWASHER - Model Number	40 °F Rise		70 °F Rise	
	6 Gallon	16 Gallon	6 Gallon	16 Gallon
	Model J6	Model J16	Model J6	Model J16
<b>INSINGER</b>				
Commander 18-5, 18-5H, Ensign 40-2	J66	J166	J612	J1612
Admiral 44-4, 66-4	J624	J1624	J636	J1639
Speeder 64, 86-3, Century (all)	J624	J1624	J645	J1645
Trac 321, Trac 321-2/RPW	J627	J1627	J645	J1645
Trac 878	J624	J1624	J636	J1636
Clipper (all), R106-2, Super 106-2	J627	J1627	J645	J1645
Defender	J636	J1636	J654	J1654
Master (all)	J636	J1636	J658	J1658
CA-3		J169		J1624
DA-3		(2) J169		(2) J1624
<b>JACKSON</b>				
JP-24, JP-24B, JP-24F, JP-24BF	J64	J166	J66	J166
24B Series			J64	J166
10AB, 10APRB			J65	J166
44CE (SEE NOTE 1), 66 CERPW	J630	J1630	J654	J1654
54CE, 76 CERPW	J636	J1636	(2) J630	(2) J1630
64CE, 86 CERPW	J627	J1627	J639	J1639
100	J612	J1612	J624	J1624
100B, 100PRB, 150B, 150PRB			J69	J169
150	J612	J1612	J618	J1618
200	J67	J167	J612	J1612
200B			J66	J166
Tempstar, Tempstar SDS, Tempstar HH	J66	J166	J612	J1612
AJ-44, AJ-66, AJ-80, WH-44, ES-4400, ES-6600 (ECOLAB/JACKSON)	J624	J1624	J645	J1645
AJ-54, AJ-76, AJ-90	J636	J1636	(2) J636	(2) J1636
AJ-64, AJ-86, AJ-100	J624	J1624	J639	J1639
NOTE 1: Model 44CE with serial no. 1999 or below requires larger booster than listed.				
<b>KNIGHT EQUIPMENT LTD.</b>				
KLE-112-HL	J67	J167	J612	J1612
<b>METALWASH/INTEDGE</b>				
FW4	J612	J1612	J618	J1618
RS-30A, RS-28L		J1615		J1624
RT-74, RT-60, RT-42B, RT-42BC		J1627		J1640
RS-2R		J1630		J1645
<b>STERO</b>				
SF-1RA, SC20-1	J67	J167	J612	J1612
SF-2RA, SF-2DRA, SD-2RA, SDRA, SDRA-PACK	J612	J1612	J618	J1618
SCT-44, SCT-44-10, SCT-54, SCT-76S, SCT-76SC, SCT-76SM	J636	J1636	J658	J1658
SCT-64, SCT-76, SCT-80, SCT-94, SCT-108, SCT-120, SCT-94S, SCT-108S, SCT-120S, SCT-94SC, SCT-108SC, SCT-120SC, SCT-94SM, SCT-120SM, SCT-150SM	J645	J1645	J658	J1658
U-31-A, U-31-AC		J1618		J1636
U-31-A2, STPCW-15, STPCW-19, STPCW-19PS, STPCW-20, STPCW-22, STPCW-24	J645	J1645	(2) J636	(2) J1636
STPCW-12PS, STPCW-15PS	J658	J1658	(2) J654	(2) J1654
STPC-12PS, STPC-15S	J654	J1654	(2) J640	(2) J1640
STPC-15, STPC-19, STPC-19S, STPC-20, STPC-22, STPC-24	J636	J1636	(2) J630	(2) J1630
STBUW-14	J658	J1658	(2) J654	(2) J1654
SC-2-4, SC-6-4, SC-1-2-4, SC-1-6-4, SC-5-6-4, SC-5-2-4	J636	J1636	J658	J1658
SC-2-3-4, SC-6-3-4, SC-2-7-4, SC-1-2-7-4, SC-1-6-3-4, SC-5-2-3-4, SC-1-6-7-4, SC-5-6-3-4, SC-5-2-7-4	J630	J1630	(2) J627	(2) J1627
SC20-2	J612	J1612	J624	J1624
SC-2-8, SC-2-9, SC-1-2-8, SC-5-6-8, SC-6-8, SC-6-9, SC-1-6-8, SC-5-6-9, SC-5-2-9, SC-1-6-9, SC-5-2-8	J618	J1618	J636	J1636
<b>VULCAN-HART</b>				
R16BTF, CU16BTF	J69	J168	J618	J1620
3D20TF, CD20TF	J612	J1612	J624	J1624
A-64 Series, A-B1 Series	J630	J1630	J654	J1654
A44 Series, A54 Series, CP-2, CP-3, HP-3	J645	J1645	(2) J640	(2) J1640

This selector chart is based upon 40 degree F and 70 degree F temperature rises, 20psi flow pressure and minimum rinse cycle timer setting in NSF listing.

All booster heaters are rated at 100% of the capacity of the dishwasher as recommended by the National Sanitation Foundation. Where make-up water for the wash tank is provided from the final rinse supply, chart recommendations are based upon this additional demand (not exceeding 2 GPM) as required by NSF.

All sizings shown are that of the dishwasher manufacturers. Hubble is not responsible for incorrect sizing applications.

# MASTER SPECIFICATION: MODEL J

JOB NAME \_\_\_\_\_

CONSULTANT \_\_\_\_\_

REPRESENTATIVE \_\_\_\_\_

DEALER/CONTRACTOR \_\_\_\_\_

## SPECIFICATIONS

Provide a quantity of \_\_\_\_\_ electric booster water heater(s) Model No. \_\_\_\_\_ as manufactured by Hubbell The Electric Heater Co. of Stratford, CT to supply the final 180°F sanitizing rinse water to the dishwasher. The pressure vessel shall be all stainless steel welded construction and shall bear the ASME Section VIII stamp and be rated for 150psi WP. The tank shall be insulated with rigid polyurethane foam insulation to reduce standby heat loss. To minimize operating expenses, heat loss shall not exceed 425 btu/hr. The booster heater shall have the capacity to heat \_\_\_\_\_ GPH from \_\_\_\_\_ to \_\_\_\_\_ °F and shall be rated at \_\_\_\_\_ KW when supplied with \_\_\_\_\_ volts, \_\_\_\_\_ phase.

The booster shall be listed and approved in accordance with UL Sanitation (NSF5) and UL1453. All controls shall be built-in and factory wired. The booster shall include internal resettable circuit breakers in lieu of one-shot power fuses for over current protection. The immersion heating elements shall be high quality screw plug type with O-ring gasket to ensure leak free long life service. All temperature, hi-limit, and low water operating functions shall be controlled by a solid state device that shall provide the operator with visual indication of fault conditions. For ease of service for any replaceable component, the positioning of all components shall be such that to remove any component does not require the removal of another component. The booster shall be complete with all internal plumbing, including  $\frac{3}{4}$ " NPT connections for inlet, outlet, and relief valve.

The entire exterior of the booster heater including the base, jacket and front cover shall be brushed 304 stainless steel for maximum corrosion resistance, longevity and appearance. Painted steel exterior will not be considered as equal.

The booster heater shall include an ASME/AGA rated combination temperature and pressure relief valve, 6" adjustable NSF plastic legs (Optional Specification: slide brackets on J6 model only), bronze body pressure reducing valve with built-in bypass, and one indicating temperature and pressure gauge. Cast iron pressure reducing valves will not be accepted as equal.

In addition, this packaged system shall be supplied with the following optional features:

- 1. Option \_\_\_\_\_
- 2. Shock Absorber
- 3. Floor Mounting Hardware
- 4. Tamper Resistant Package
- 5. Nickel Plated Die-Cast Leg
- 6. Alternate Voltage

The entire pressure vessel shall be provided with a full ten (10) year **Non Pro-Rated** tank warranty. A ten year pro-rated warranty shall not be considered as equal. The entire booster heater including all components shall be provided with a one-year warranty including parts and labor.

## WATER QUALITY REQUIREMENTS

Recommended water hardness is 4 to 6 grains of hardness per gallon (GPG). Water hardness above 6 GPG should be treated by a water conditioner (water softener or in-line treatment). Water hardness below 4 GPG also requires treatment to reduce potential corrosion. Excessive GPG will result in higher operating and maintenance costs and will reduce product longevity.

Chlorides must not exceed 50 parts per million (ppm). Excessive chlorides will result in metallic corrosion and will reduce product longevity.

Water treatment has been shown to reduce costs associated with deliming the booster as well as reducing metallic corrosion. Product failure caused by these conditions is not covered under warranty. See warranty for complete details.

*Continuing research results in product improvement; therefore these specifications are subject to change without notice. For the most updated information, consult the factory.*

**Hubbell**™

ISO 9001:2000 ISO

